

OWNER'S GUIDE & INSTALLATION INSTRUCTIONS

Thru-Hull: *Low-Profile, Flush & Retractable* Shorty™ Depth Transducer

Models: P6, P7, P8, P208

Record the information found on the cable tag for future reference.

Part No. _____ Date _____ Frequency _____ kH

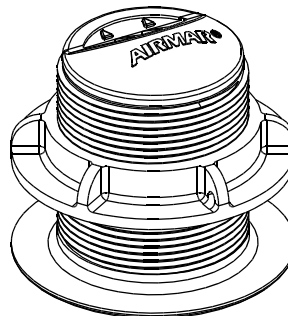

P7
Low profile

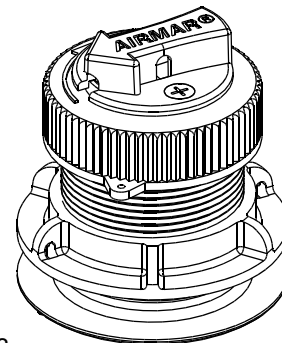

P8
Low profile, retractable

Follow the precautions below for optimal product performance and to reduce the risk of property damage, personal injury, and/or death.

WARNING: Always wear safety goggles and a dust mask when installing.

WARNING: Immediately check for leaks when the boat is placed in the water. Do not leave the boat unchecked for more than three hours. Even a small leak may allow considerable water to accumulate.

WARNING: Retractable models—The O-rings must be intact and well lubricated to make a watertight seal.

WARNING: Retractable models—Always attach the safety wire to prevent the sensor insert or blanking plug from backing out in the unlikely event that the cap nut fails or is screwed on incorrectly.

CAUTION: Never pull, carry, or hold the sensor by its cable; this may sever internal connections.

CAUTION: Never use a fairing with a plastic housing; the protruding sensor would be vulnerable to damage from impact.

CAUTION: The arrow on the top of the transducer insert and the flange of the housing must point forward toward the bow.

CAUTION: Never use solvents. Cleaner, fuel, sealant, paint, and other products may contain solvents that can damage plastic parts, especially the transducer's face.

IMPORTANT: Please read the instructions completely before proceeding with the installation. These instructions supersede any other instructions in your instrument manual if they differ.

Applications

- Recommended for fiberglass or metal hulls only
- *Never install a plastic housing in a wood hull, since swelling of the wood may fracture the plastic.*
- Low profile housing recommended for cruising sailboats and planing hull powerboats
- Flush housing recommended for racing sailboats and high-speed powerboats
- Accommodates up to a 20° deadrise angle.

Tools & Materials

Safety goggles
Dust mask
Electric drill with minimum 10mm (3/8") chuck capacity
Drill bit 3mm or 1/8"
Hole saw 51 mm or 2"
Countersink tool (installing P208 flush housing)
Sandpaper
Mild household detergent or weak solvent (such as alcohol)
File (installation in a metal hull)
Marine sealant (suitable for below waterline)
Additional washer [aluminum hull less than 6mm (1/4") thick]
Grommet(s) (some installations)
Cable ties
Water-based antifouling paint (**mandatory in salt water**)
Installation in a cored fiberglass hull (see page 3):
Hole saw for hull interior 60mm or 2-3/8"
Fiberglass cloth and resin
or Cylinder, wax, tape, and casting epoxy

Identify Your Model

The model name is printed on the cable tag.

Hull Thickness

Model	Minimum	Maximum
P6, P7 (low profile)	6mm (1/4")	38mm (1 1/2")
P8 (low profile, retractable)	6mm (1/4")	25mm (1")
P208 (flush, retractable)	11mm (7/16")	30mm (1 3/16")

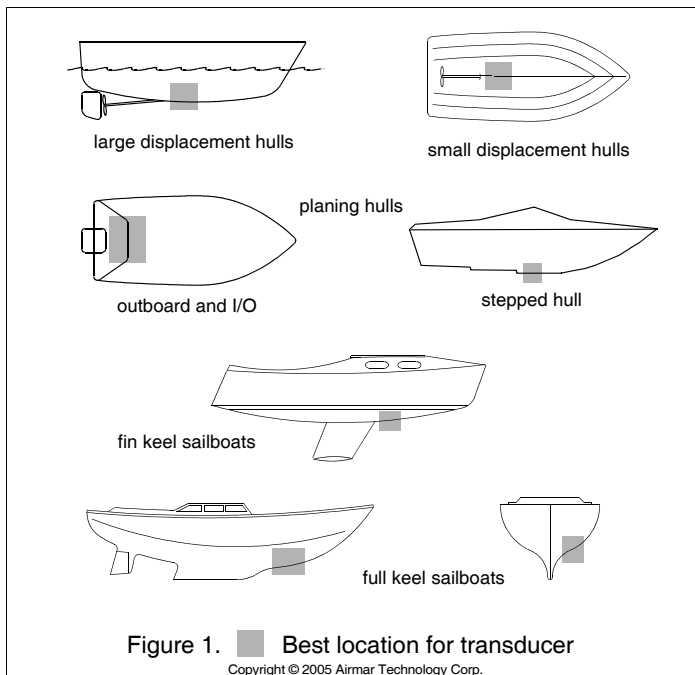

Mounting Location

Guidelines

CAUTION: Do not mount the transducer in line with or near water intake or discharge openings; or behind strakes, fittings or hull irregularities that may disturb the water flow.

CAUTION: Do not mount the transducer where the boat may be supported during trailering, launching, hauling, or storage to avoid damaging the transducer's face.

- The water flowing under the hull must be smooth with a minimum of bubbles and turbulence (especially at high speeds).
- The transducer must be continuously immersed in water.
- The transducer beam must be unobstructed by the keel or propeller shaft(s).
- Choose a location away from interference caused by power and radiation sources such as: the propeller(s) and shaft(s), other machinery, other echosounders, and other cables. The lower the noise level, the higher the echosounder gain setting that can be used.
- Choose a location with a minimal deadrise angle, so the transducer beam will be aimed toward the bottom.
- Choose an accessible spot inside the vessel with adequate headroom for the height of the housing, tightening the nuts, and removing any insert.

Model	Minimum Headroom
P6, P7	76mm (3")
Retractable P8, P208	153mm (6")

Boat Types (see Figure 1)

- **Displacement hull powerboats**—Locate amidships near the centerline. The starboard side of the hull where the propeller blades are moving downward is preferred.
- **Planing hull powerboats**—Mount well aft, on or near the centerline, and well inboard of the first set of lifting strakes to ensure that the transducer will be in contact with the water at high speeds. The starboard side of the hull where the propeller blades are moving downward is preferred.
- **Outboard and I/O**—Mount just forward of the engine(s).
- **Inboard**—Mount well ahead of the propeller(s) and shaft(s).
- **Stepped hull**—Mount just ahead of the first step.
- **Boat capable of speeds above 25kn (29MPH)**—Review the

installation location and operating results of similar boats before proceeding.

- **Fin keel sailboats**—Mount on or near the centerline and forward of the fin keel 300–600mm (1–2').
- **Full keel sailboats**—Locate amidships and away from the keel at the point of minimum deadrise.

Installation

Hole Drilling

Cored fiberglass hull—Follow separate instructions on page 3.

1. Drill a 3mm or 1/8" pilot hole from inside the hull. If there is a rib, strut, or other hull irregularity near the selected mounting location, drill from the outside.
2. Using a 51 mm or 2" hole saw, cut a hole perpendicular to the hull from outside the hull.

P208 flush housing—Use a countersink tool to make a "seat" in the hull.

3. Sand and clean the area around the hole, inside and outside, to ensure that the sealant will adhere properly to the hull. If there is any petroleum residue inside the hull, remove it with either mild household detergent or a weak solvent (alcohol) before sanding.

Metal hull—Remove all burrs with a file and sandpaper.

Bedding

CAUTION: Be sure the surfaces to be bedded are clean and dry.

Apply a 2mm (1/16") thick layer of marine sealant around the flange and up the sidewall of the housing that will contact the hull (see Figure 2). The sealant must extend 6mm (1/4") higher than the combined thickness of the hull, any washer(s), and the hull nut. This will ensure there is sealant in the threads to seal the hull and hold the hull nut securely in place.

Installing

1. From outside the hull, push the housing (and cable if applicable) into the mounting hole using a twisting motion to squeeze out excess marine sealant. *Align the arrow on the flange of the housing to point forward toward the bow* (see Figure 2).
2. From inside the hull, slide any washer(s) onto the housing.

NOTE: Some installations do not have a washer.

Aluminum hull less than 6mm (1/4") thick—Use an additional rubbery, plastic, or fiberglass washer. Never use bronze because electrolytic corrosion will occur. Never use wood because it will swell, possibly fracturing the plastic housing.

3. Screw the hull nut into place, being sure the notch on the upper rim of the housing is still positioned forward toward the bow. **Hand-tighten** only. Do not over-tighten.

Plastic housing—Do not clamp tightly on the wrench flats possibly fracturing the housing.

Cored Fiberglass Hull—Do not over tighten, crushing the hull.

4. Remove the excess sealant on the outside of the hull to ensure smooth water flow under the transducer.

Retractable Models

1. After the sealant cures, inspect the O-rings on the transducer insert (replace if necessary) and lubricate them with the silicone lubricant supplied (see Figure 3). The O-rings must be intact and well lubricated to make a watertight seal.
2. *Slide the insert into the housing with the arrow on the top pointing forward toward the bow.* Seat it into place with a pushing twisting motion until the key fits into the notch (see Figure 2). The arrow on the top of the insert, the notch, and the arrow on the flange of the housing will all be aligned. Be careful not to rotate the housing and disturb the marine sealant.

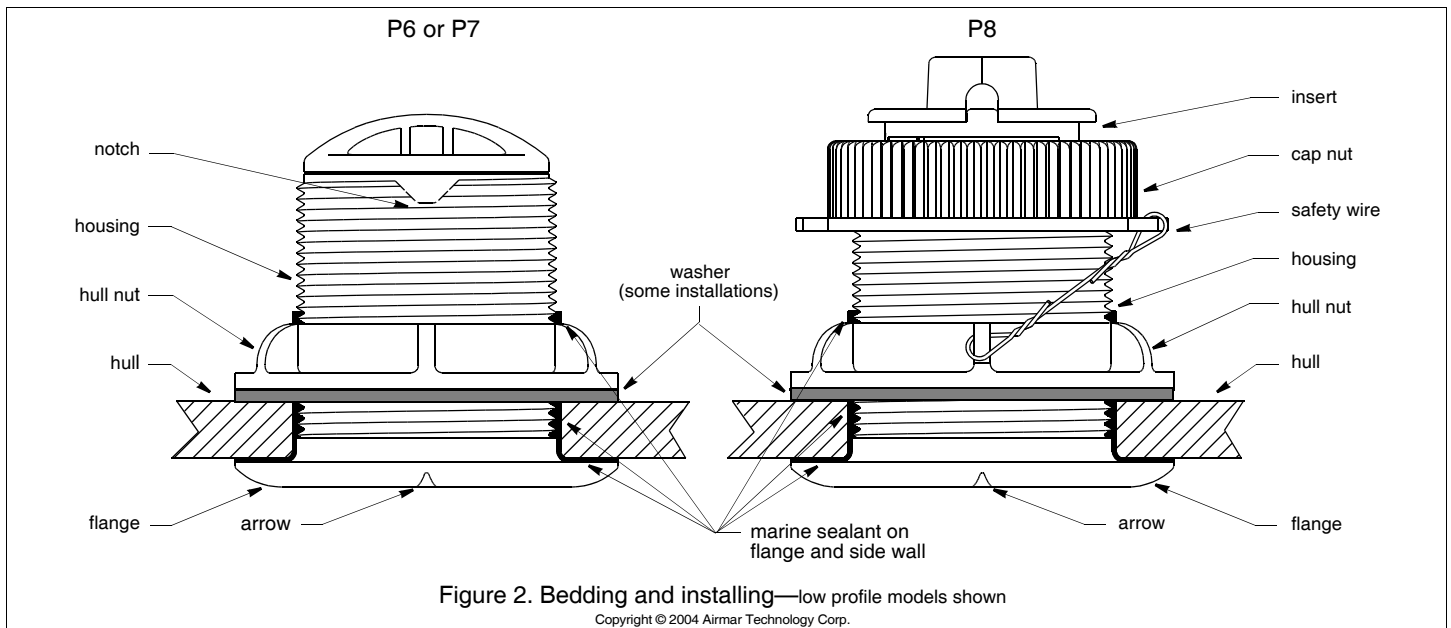

3. Screw the cap nut several turns, then check that the arrow on the insert is still facing forward toward the bow. Continue to tighten the cap nut. **Hand-tighten** only. Do not over tighten.
4. Attach the safety wire to prevent the insert from backing out in the unlikely event that the cap nut fails or is screwed on incorrectly. Attach the safety wire to one eye in the hull nut. Keeping the wire taut throughout, lead the wire in a counterclockwise direction and thread it through one eye in the cap nut. Twist the end securely to the wire.

Cable Routing & Connecting

CAUTION: If your sensor came with a connector, do not remove it to ease cable routing. If the cable must be cut and spliced, use Airmar's splash-proof Junction Box No. 33-035 and follow the instructions provided. Removing the waterproof connector or cutting the cable, except when using a watertight junction box, will void the sensor's warranty.

1. Route the cable to the instrument, being careful not to tear the cable jacket when passing it through the bulkhead(s) and other parts of the boat. Use grommets to prevent chafing. To reduce electrical interference, separate the transducer cable from other electrical wiring and the engine. Coil any excess cable and secure it in place with cable ties to prevent damage.
2. Refer to the instrument owner's manual to connect the transducer to the instrument.

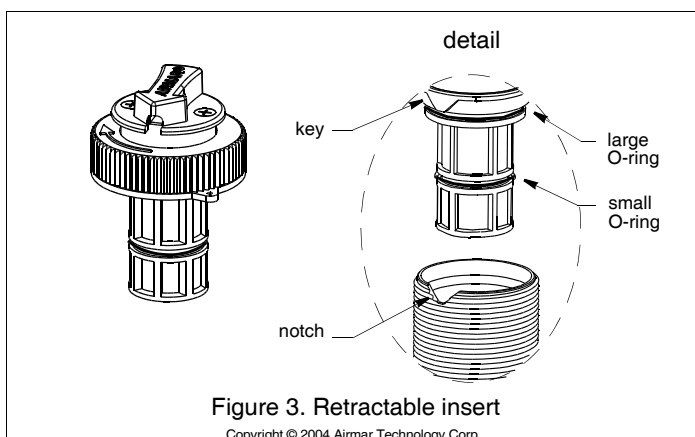

Checking for Leaks

When the boat is placed in the water, **immediately** check around the thru-hull transducer for leaks. Note that very small leaks may not be readily observed. Do not leave the boat in the water for more than 3 hours before checking it again. If there is a small leak, there may be considerable bilge water accumulation after 24 hours. If a leak is observed, repeat "Bedding" and "Installing" **immediately** (see page 2).

Installation in a Cored Fiberglass Hull

The core (wood or foam) must be cut and sealed carefully. The core must be protected from water seepage, and the hull must be reinforced to prevent it from crushing under the hull nut allowing the housing to become loose.

CAUTION: Completely seal the hull to prevent water seepage into the core.

1. Drill a 3mm or 1/8" pilot hole from inside the hull. If there is a rib, strut, or other hull irregularity near the selected mounting location, drill from the outside. (If the hole is drilled in the wrong location, drill a second hole in a better location. Apply masking tape to the outside of the hull over the incorrect hole and fill it with epoxy.)
2. Using a 51 mm or 2" hole saw, cut a hole from outside the hull through the *outer skin* only (see Figure 4).

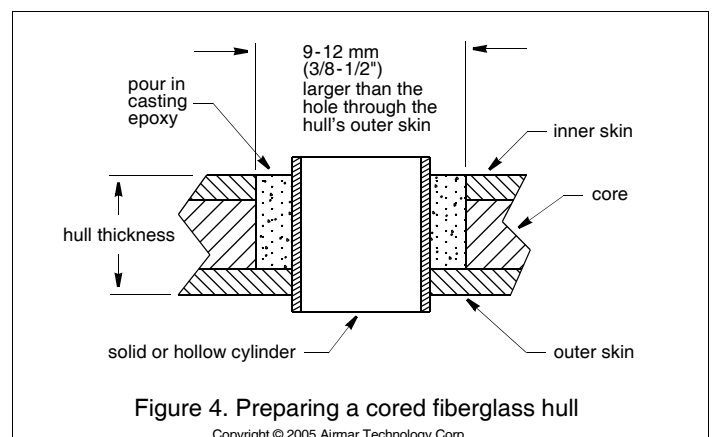

- From inside the hull, use a 60mm or 2-3/8" hole saw, to cut through the *inner* skin and most of the core. The core material can be very soft. Apply only light pressure to the hole saw after cutting through the inner skin to avoid accidentally cutting the *outer* skin.
- Remove the plug of core material, so the *inside* of the outer skin and the inner core of the hull is fully exposed. Sand and clean the inner skin, core, and the outer skin around the hole.
- If you are skilled with fiberglass, saturate a layer of fiberglass cloth with a suitable resin and lay it inside the hole to seal and strengthen the core. Add layers until the hole is the correct diameter.
Alternatively, a hollow or solid cylinder of the correct diameter can be coated with wax and taped in place. Fill the gap between the cylinder and hull with casting epoxy. After the epoxy has set, remove the cylinder.
- Sand and clean the area around the hole, inside and outside, to ensure that the sealant will adhere properly to the hull. If there is any petroleum residue inside the hull, remove it with either mild household detergent or a weak solvent (alcohol) before sanding.
- Proceed with "Bedding" and "Installing" on page 2.

Maintenance, Parts & Replacement

Antifouling Paint

Surfaces exposed to salt water must be coated with antifouling paint. *Use water-based antifouling paint only.* Never use ketone based antifouling paint, since ketones can attack many plastics possibly damaging the transducer. Reapply antifouling paint every 6 months or at the beginning of each boating season.

Retractable Models—Paint the following surfaces:

- Outside wall of the insert below lower O-ring and exposed end
- Bore of the housing up 30mm (1-1/4")
- Exterior flange of the housing
- Blanking plug below the lower O-ring including the exposed end

Retractable Models

Using the Blanking Plug

CAUTION: Do not remove the screws on the top of the transducer.

To protect the insert, use the blanking plug:

- When the boat will be kept in salt water for more than a week.
- When the boat will be removed from the water.
- When aquatic growth buildup on the insert is suspected due to inaccurate readings from the instrument.

- The O-rings must be intact and well lubricated to make a watertight seal. On the blanking plug, inspect the O-rings (replace if necessary) and lubricate them with the silicone lubricant supplied or petroleum jelly (Vaseline®) (see Figure 3).

- Remove the transducer insert from the housing by removing the safety wire from the cap nut (see Figure 2). Unscrew the cap nut. This will jack the insert out of the housing, removing the cap nut and insert as a single unit.
- With the blanking plug ready in one hand, pull the transducer insert out. Rapidly replace it with the blanking plug. Seat it into place with a pushing twisting motion until the key fits into the notch in the housing (see Figure 3). With practice, only 250ml (10oz.) of water will enter the boat. Screw the cap nut in place and **hand-tighten** only. Do not over tighten.
- Reattach the safety wire to prevent the blanking plug from backing out in the unlikely event that the cap nut fails or is screwed on incorrectly (see Figure 2).

Winterizing

After the boat has been hauled for winter storage, remove the blanking plug to let the water drain away before reinserting it. This will prevent any water from freezing around the blanking plug, possibly cracking the plastic.

Cleaning

Aquatic growth can accumulate rapidly on the transducer's face, reducing its performance within weeks. Clean it using a Scotch-Brite® scour pad and mild household detergent, being careful to avoid making scratches. If the fouling is severe, lightly wet sand the surface with fine grade wet/dry paper.

Replacement Transducer & Parts

The information needed to order a replacement Airmar transducer is printed on the cable tag. Do not remove this tag. When ordering, specify the part number, date, and frequency in kHz. For convenient reference, record this information on the top of page one.

Lost, broken, and worn parts should be replaced immediately.

Model	Housing & Nut	Rubber Washer	Hull Nut	Cap Nut	O-Rings	Blanking Plug
P6, P7	—	09-452	04-004	—	—	—
P8 retractable	33-360-01	09-452	04-004	04-011	33-519-01	20-291-01
P208 retractable	33-468-01	09-452	04-004	04-011	33-519-01	20-291-01

Obtain parts from your instrument manufacturer or marine dealer.

Gemeco

Tel: 803.693.0777

(USA)

Fax: 803.693.0477

Email: sales@gemeco.com

Airmar EMEA

Tel: +33.(0)2.23.52.06.48

(Europe, Middle East, Africa)

Fax: +33.(0)2.23.52.06.49

Email: sales@airmar-emea.com