

OWNER'S GUIDE &

INSTALLATION INSTRUCTIONS

Thru-Hull, Retractable Long-stem Sensors

Models: B122, DST800L, ST700

U.S. Patents.: 6,904,798; 7,110,908; 7,352,171. UK Patents: 2 407 874; 2 409 527

05/15/11

17-284-01 rev. 05

Follow the safety precautions below to reduce the risk of poor product performance, property damage, personal injury, and/or death.

WARNING: Always wear safety goggles and a dust mask when installing.

WARNING: Fairing—The High-Performance Fairing requires an anti-rotation bolt. Failure to install the anti-rotation bolt may result in the fairing rotating while the boat is underway. The effect may be violent movement and loss of steering.

WARNING: Fairing—The fairing must be installed parallel to the keel to ensure proper boat handling.

WARNING: Fairing—Do not install a fairing that has been mis-cut. Replace it. Failure to do so may result in the fairing rotating while the boat is underway.

- Cutting the fairing at an angle greater than the 35° maximum allowed will cut into the sensor and/or bolt pocket, thus weakening the fairing.
- Do not allow any gap between the fairing and the hull that is greater than 3mm (1/8"). When the boat is underway, water will enter any gaps and push against the fairing with considerable force.

WARNING: Do not over tighten the hull nut and nut on the anti-rotation bolt, crushing the hull and/or fairing.

WARNING: The O-rings must be intact and well lubricated to make a watertight seal.

WARNING: The valve is not a watertight seal! Be sure the insert or blanking plug is fully inserted into the housing, and the cap nut is screwed on completely.

WARNING: Always attach the safety wire to prevent the insert or blanking plug from backing out in the unlikely event that the cap nut fails or is screwed on incorrectly.

WARNING: Immediately check for leaks when the boat is placed in the water. Do not leave the boat unchecked for more than three hours. Even a small leak may allow considerable water to accumulate.

CAUTION: Never install a metal sensor on a vessel with a positive ground system.

CAUTION: Never pull, carry, or hold the sensor by its cable; this may sever internal connections.

CAUTION: Never strike the sensor.

CAUTION: The arrow on the top of the insert must point forward toward the bow when installed.

CAUTION: Never use solvents. Cleaners, fuel, sealants, paint, and other products may contain strong solvents, such as acetone, which attack many plastics, greatly reducing their strength.

Record the information found on the cable tag for future reference.

PN: _____ Date _____ Frequency _____ kHz

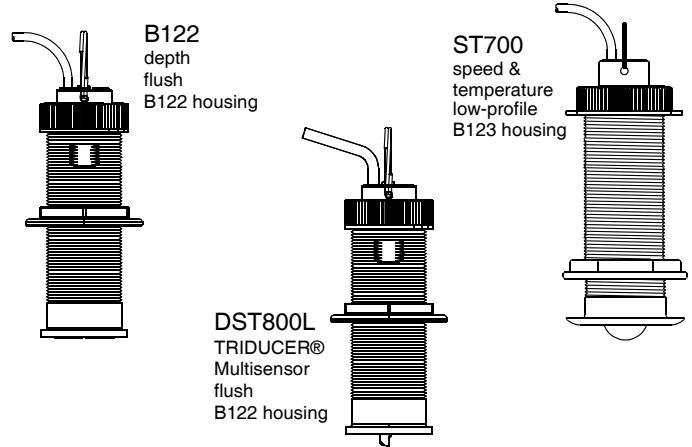

IMPORTANT: Read the instructions completely before proceeding with the installation. These instructions supersede any other instructions in your instrument manual if they differ.

Application

- Recommended for a thick hull.
- Bronze housing recommended for fiberglass or wood hull. *Never install a bronze housing in a metal hull because electrolytic corrosion will occur.*
- Flush-mount accommodates a deadrise angle up to 10°.
- Fairing accommodates a deadrise angle up to 28°.
- Maximum hull thickness with 35° deadrise angle and fairing (measured perpendicular to the water surface): 47 mm (1-7/8")

Pretest

Connect the insert to the instrument and spin the paddlewheel if any. Check for the approximate air temperature and any speed reading. If there is no reading(s), check all the connections and repeat the test. If there is still no reading(s) or it is inaccurate, return the product to your place of purchase.

Tools & Materials

- Safety goggles
- Dust mask
- Water-based anti-fouling paint (**mandatory in salt water**)
- Electric drill with 10mm (3/8") or larger chuck capacity
- Drill bits: 3 mm or 1/8" (pilot hole)
11 mm or 7/16" (anti-rotation bolt hole)
- Hole saw: 51 mm or 2" (flush mount)
57 mm or 2-1/4" (installation with adapter ring)
- Angle finder (some installations)
- Band saw (fairing installation)
- Rasp or power tool (fairing installation)
- Sandpaper
- Mild household detergent or weak solvent (such as alcohol)
- Marine sealant (suitable for below waterline)
- Slip-joint pliers
- Mallet (some installations)
- Countersink tool (flush installation)
- Grommet(s) (some installations)
- Cable ties
- Installation in a cored fiberglass hull (see page 6)
 - Hole saw for hull interior:
 - Sensor: min. 60mm or 2-3/8"
 - Anti-rotation bolt: min. 19mm or 3/4"
 - Cylinder, wax, tape, and casting epoxy

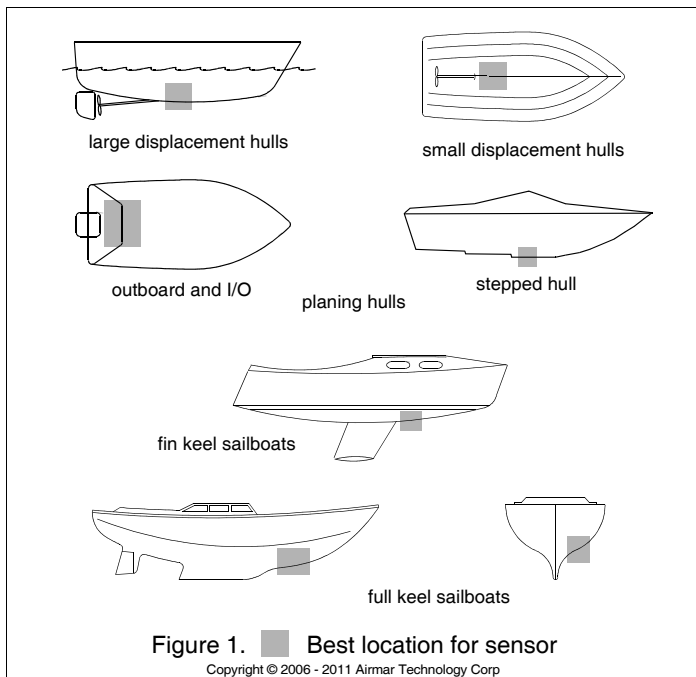

Mounting Location

CAUTION: Do not mount near water intake or discharge openings, or behind strakes, fittings, or hull irregularities that will disturb the water flow.

CAUTION: Never mount the speed sensor directly ahead of a depth transducer, since turbulence generated by the paddlewheel's rotation will adversely effect the depth transducer's performance, especially at high speeds. Mount side-by-side.

- The water flowing under the hull must be smooth with a minimum of bubbles and turbulence (especially at high speeds).
- The sensor must be continuously immersed in water.
- The transducer beam must be unobstructed by the keel or propeller shaft(s).
- Choose a location away from interference caused by power and radiation sources such as: the propeller(s) and shaft(s), other machinery, other echosounders, and other cables. The lower the noise level, the higher the echosounder gain setting that can be used.
- If the sensor will be installed without a fairing, choose a location with a minimal deadrise angle, less than 10° , so the transducer beam will be aimed at the bottom.
- Choose an accessible spot inside the vessel with adequate headroom for the height of the housing, tightening the nuts, and removing insert. Allow a minimum of 200mm (7-3/4") above the top of the housing.

Hull Types (see Figure 1)

- **Displacement hull powerboat**—Locate amidships near the centerline. The starboard side of the hull where the propeller blades are moving downward is preferred.
- **Planing hull powerboat**—Mount well aft, on or near the centerline, and *well inboard of the first set of lifting strakes* to ensure that the sensor will be in contact with the water at high speeds. The starboard side of the hull where the propeller blades are moving downward is preferred.
- **Outboard and I/O**—Mount just forward of the engine(s).
- **Inboard**—Mount well ahead of the propeller(s) and shaft(s).
- **Stepped hull**—Mount just ahead of the first step.
- **Boat capable of speeds above 25kn (29MPH)**—Review the

installation location and operating results of similar boats before proceeding.

- **Fin keel sailboat**—Mount on or near the centerline and forward of the fin keel 300–600mm (1–2').
- **Full keel sailboat**—Locate amidships and away from the keel at the point of minimum deadrise angle.

About the High-Performance Fairing

Nearly all vessels have some deadrise angle at the mounting location. If the sensor is mounted directly to the hull, the transducer beam will be tilted to the side at the same angle as the deadrise. A fairing is strongly recommended if the deadrise angle exceeds 10° .

- Orients the transducer beam straight down by mounting the sensor parallel to the water surface (see Figure 3).
- Mounts the sensor deeper in the water for clean flow under the transducer face.
- Long streamlined shape directs the water around the sensor to minimize drag.

Anti-fouling Paint

Marine growth can accumulate rapidly on the sensor's surface reducing performance in weeks. Surfaces exposed to salt water must be coated with anti-fouling paint. *Use water-based anti-fouling paint only.* Never use ketone-based paint, since ketones can attack plastics possibly damage the sensor.

It is easier to apply antifouling paint before installation, but allow sufficient drying time. Reapply paint every 6 months or at the beginning of each boating season. Paint the following surfaces (see Figure 2):

- Exterior flange of housing
- Bore of housing up 30mm (1-1/4")
- Insert and Blanking Plug:
 - B122, Blanking Plug—Outside wall below lower joint
Exposed end
 - DST800L, ST700—Outside wall below lowest O-ring
Any exposed end
Paddlewheel
Paddlewheel cavity

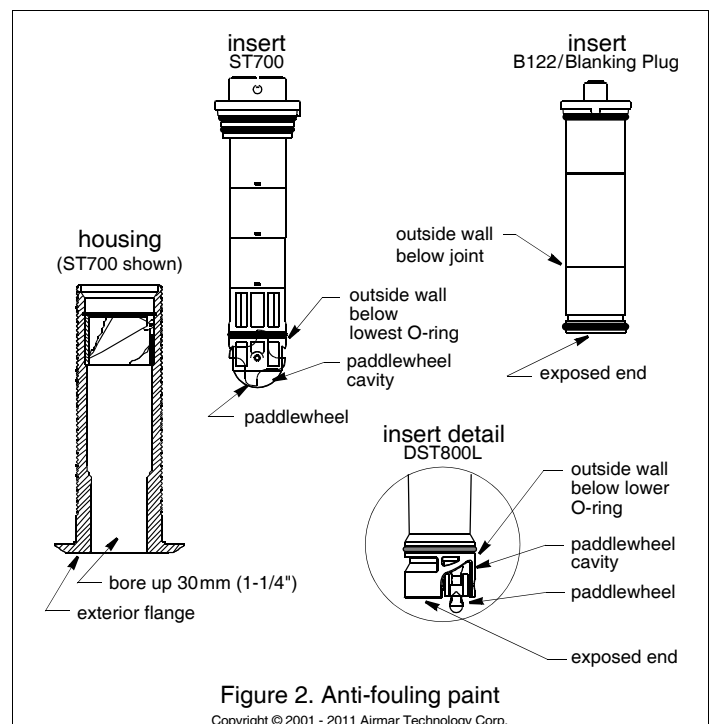

WARNING

Installation of the anti-rotation bolt is mandatory in a High-Performance Fairing!
Failure to install the anti-rotation bolt may result in the fairing rotating while the boat is underway. The effect may be violent movement and loss of steering. This could result in serious injury or death to passengers and/or damage to the boat or other property.

Installation with Fairing: Suitable for B122, DST800L

Hole Drilling: Sensor

Cored fiberglass hull—Follow separate instructions on page 7.

1. Drill a 3mm or 1/8" pilot hole perpendicular to the waterline from inside the hull. If there is a rib, strut, or other hull irregularity near the selected mounting location, drill from the outside.
2. Using the 51 mm or 2" hole saw, cut a hole from outside the boat (see Figure 3). Be sure to hold the drill plumb, so the hole will be perpendicular to the water surface.

Cutting the Fairing

CAUTION: The end of the fairing with the arrows/triangular recess always points forward toward the bow when installed. Be sure to orient the fairing on the band saw so the angle cut matches the intended side of the hull and not the mirror image.

CAUTION: The housing must be flush with the fairing for smooth water flow under the sensor.

1. Measure the deadrise angle of the hull at the selected mounting location using an angle finder (see Figure 3). *Check to be sure the angle does not exceed the 35° maximum allowed.*
2. Tilt the band saw table to the measured angle and secure the cutting fence (see Figure 4).
3. Place the fairing on the table so the cutting guide rests against the fence (see Figures 4 and 5). The end with the triangular recess will be pointing *toward* you for installation on the starboard side of the boat or pointing *away* from you for installation on the port side.
4. Adjust the cutting fence so the fairing will be cut in about two equal parts. The section that will become the fairing must be a minimum of 13mm (1/2") at its thinnest dimension (see Figure 3). Cutting the fairing at an angle greater than 35° will cut into the sensor and/or bolt pocket, thus weakening the fairing.

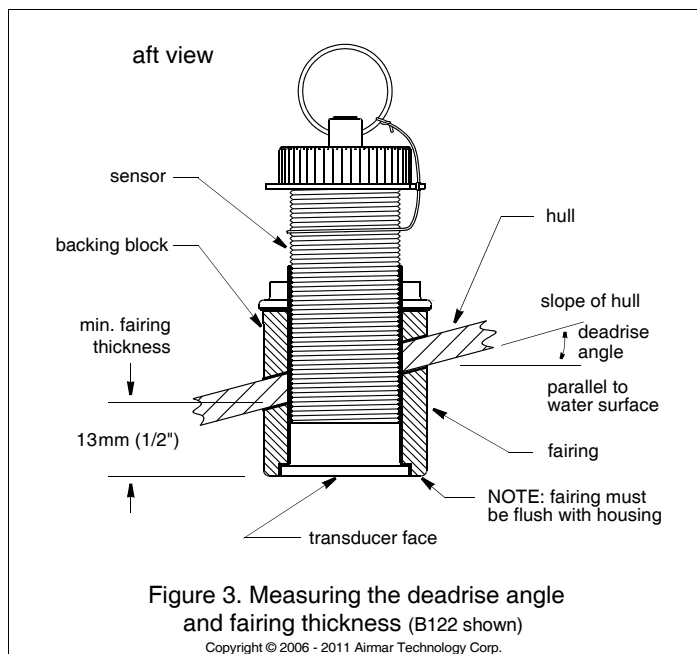
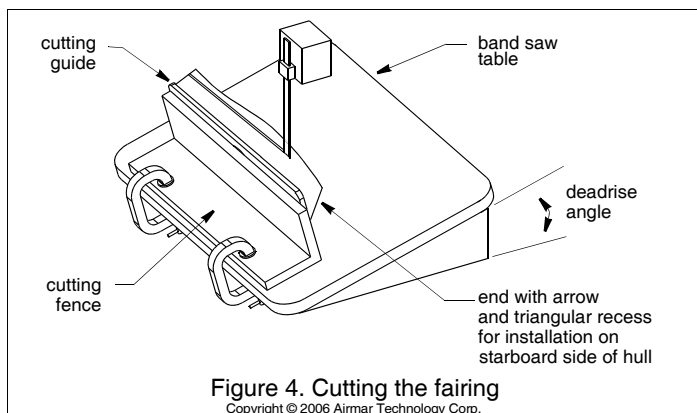

5. Recheck steps 1 through 4. Then cut the fairing.
6. When the boat is underway, especially at high speeds, water will enter gaps and push against the fairing with considerable force. Shape the fairing to the hull as precisely as possible with a rasp or power tool. *If there is a gap of more than 3mm (1/8"), replace the fairing.*
7. Check to be sure the housing is flush with the fairing. If it is recessed more than 0.5mm (1/64") inside the fairing, you may shim the housing or carefully file/sand the fairing.
8. Use the remaining section of the fairing with the cutting guide for the backing block.

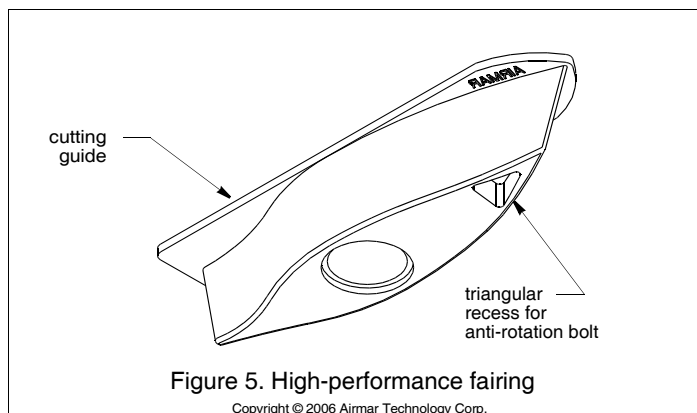

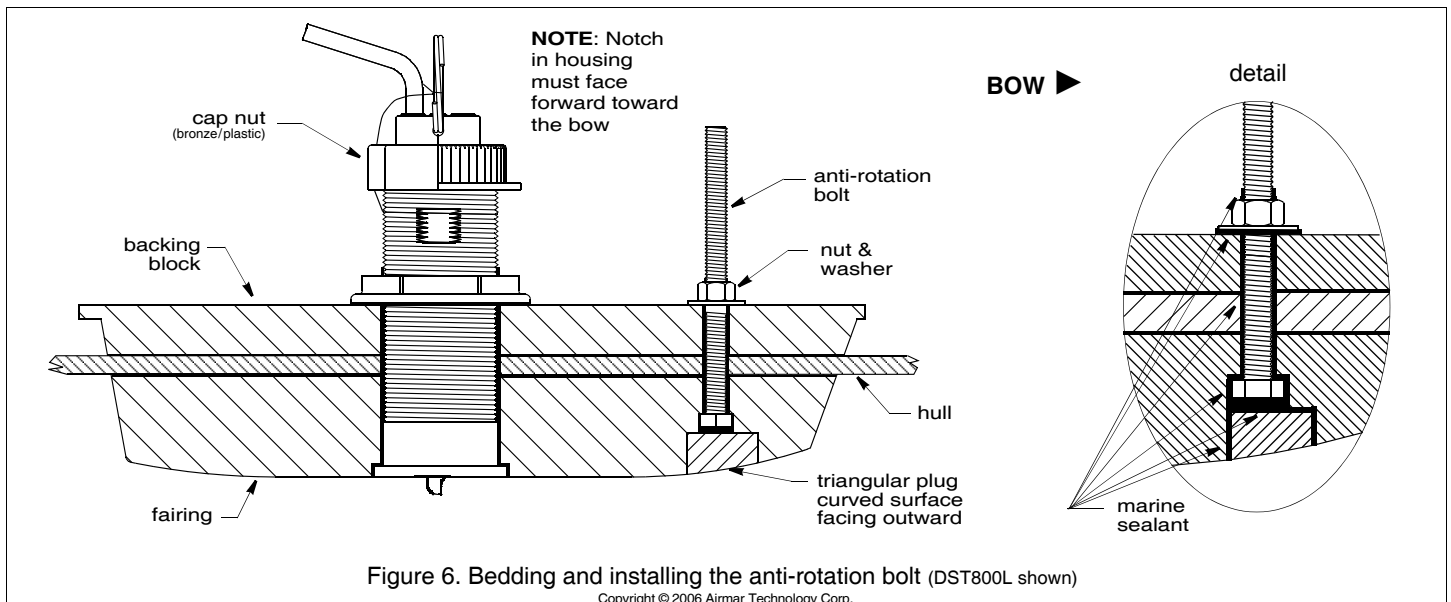

Hole Drilling: Anti-rotation Bolt

Cored fiberglass hull—Follow separate instructions on page 7.

To locate and drill the hole for the anti-rotation bolt, use the fairing as a guide. This will ensure that the hole is perpendicular to the waterline and not drilled at the angle of the hull.

1. Dry fit the housing in the fairing. Seat the housing firmly in the recess in the fairing (see Figure 6).
2. Slide the housing with the fairing in place into the mounting hole. **Hold the fairing parallel to the keel with the triangular recess in the fairing is pointing forward toward the bow.** Using the bolt hole in the fairing as your guide, drill a 3mm or 1/8" pilot hole through the hull for the anti-rotation bolt.
3. With the 11 mm or 7/16" bit and using the bolt hole in the fairing as your guide, drill the hole through the hull for the anti-rotation bolt.
4. Remove the assembly from the mounting hole.

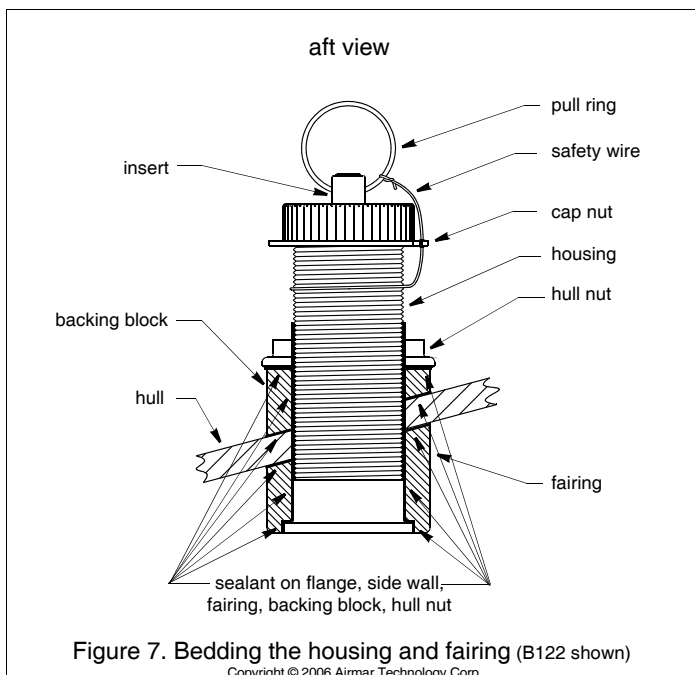

5. Sand and clean the area around both holes, inside and outside, to ensure that the sealant will adhere properly to the hull. If there is any petroleum residue inside the hull, remove it with either mild household detergent or a weak solvent, (alcohol) before sanding.

Bedding the Housing & Fairing

CAUTION; Be sure the surfaces to be bedded are clean and dry.

1. Remove the housing from the fairing.
2. Apply a 2mm (1/16") thick layer of marine sealant around the flange of the housing that will contact the fairing and up the sidewall of the housing (see Figure 7). *The sealant must extend 6mm (1/4") higher than the combined thickness of the fairing, hull, backing block, and the hull nut.* This will ensure there is sealant in the threads to seal the hull and to hold the hull nut securely in place.
3. Apply a 2mm (1/16") thick layer of marine sealant to the following surfaces:
 - Fairing that will contact the hull
 - Backing block that will contact the hull.
 - Hull nut that will contact the backing block

Installing the Housing & Fairing

1. Seat the housing firmly within the recess in the fairing (see Figure 6). *Align the notch in the top of the housing pointing forward toward the anti-rotation bolt hole (bow).*
2. From outside the hull, push the housing (with the fairing in place) into the mounting hole using a twisting motion to squeeze out excess sealant.
3. From inside the hull, Slide the backing block onto the housing. Seat the backing block firmly against the hull.
4. Screw the hull nut in place. *Do not tighten at this time.*

Bedding & Installing the Anti-rotation Bolt

CAUTION: Be sure the surfaces to be bedded are clean and dry.

CAUTION: For smooth water flow under the sensor be sure the external surface of the triangular plug is flush with the curved surface of the fairing.

1. Apply a 2mm (1/16") thick layer of marine sealant to the anti-rotation bolt *including the flange* (see Figure 6). *The sealant must extend 6mm (1/4") higher than the combined thickness of*

the fairing, hull, backing block, washer, and nut. This will ensure that there is marine sealant on the threads to seal the hull and hold the nut securely in place.

2. Apply a 2mm (1/16") thick layer of marine sealant to the surface of the washer that will contact the backing block.
3. Push the anti-rotation bolt through the fairing and into the hull.
4. From inside the hull, screw the washer (sealant side down) and the nut onto the anti-rotation bolt.
5. Use slip-joint pliers to tighten both the hull nut and the anti-rotation bolt. *Do not over tighten crushing the fairing or hull.*

Cored fiberglass hull—Do not over tighten crushing the hull.
Wood hull—Allow for the wood to swell.

6. Use marine sealant to over-fill the hollow in the yellow triangular plug. Apply a 2mm (1/16") thick layer of marine sealant to the three sides of the plug that form the triangle. The sealant will hold the plug firmly within the fairing and fill any gap between the anti-rotation bolt and the plug.
7. *The yellow triangular plug fits one way only.* Push the yellow plug into the recess in the fairing until it is **FLUSH** with the outside of the fairing. This will squeeze out excess sealant. If necessary, tap it into place with a mallet.

NOTE: *If the triangular plug is slightly recessed within the fairing, use sealant to fill the gap. The plug must be flush with the fairing for good performance.*

8. When the boat is underway, especially at high speeds, water will enter gaps and push against the fairing with considerable force. Fill any gaps between the fairing and the hull with marine sealant. **If there is any gap greater than 3mm (1/8"), replace the fairing.** Remove the excess sealant on the outside of the fairing and hull to ensure smooth water flow under the sensor.
9. Continue with "Installing the Insert" on page 6.

Flush & Low-Profile Mount: Suitable for All Models Hole Drilling

Cored fiberglass hull—Follow separate instructions on page 7.

1. Drill a 3 mm or 1/8" pilot hole from inside the hull. If there is a rib, strut, or other hull irregularity near the selected mounting location, drill from the outside.
2. Using the appropriate size hole saw, cut a hole perpendicular to the hull from outside the boat (see figure 8).

Flush housing—Use a countersink tool to make a 'seat' in the hull.

3. Sand and clean the area around the hole, inside and outside, to ensure that the marine sealant will adhere properly to the hull. If there is any petroleum residue inside the hull, remove it with either mild household detergent or a weak solvent before sanding.

Bedding

CAUTION: Be sure the surfaces to be bedded are clean and dry.

Apply a 2mm (1/16") thick layer of marine sealant around the flange of the housing that will contact the hull and up the sidewall of the housing (see Figure 8). *The sealant must extend 6mm (1/4") higher than the combined thickness of the hull, washer, the hull nut, and any adaptor ring.* This will ensure there is sealant in the threads to seal the hull and to hold the hull nut securely in place.

Adaptor ring—Slide the adaptor ring onto the housing. Apply *additional* marine sealant to the surfaces of the ring that will contact the hull, filling any cavities in and around the ring.

Installing

1. From outside the hull, push the housing into the mounting hole using a twisting motion to squeeze out excess marine sealant (see Figure 8). *Align the notch in the top of the housing pointing forward toward the bow.*
2. From inside the hull, slide the washer onto the housing.
3. Screw the hull nut in place, being sure the notch is still positioned forward toward the bow. Tighten with slip-joint pliers.
Cored Fiberglass Hull—Do not over tighten, crushing the hull.
Wood hull—Allow the wood to swell before tightening the hull nut.
4. Remove any excess marine sealant on the outside of the hull to ensure smooth water flow under the sensor.

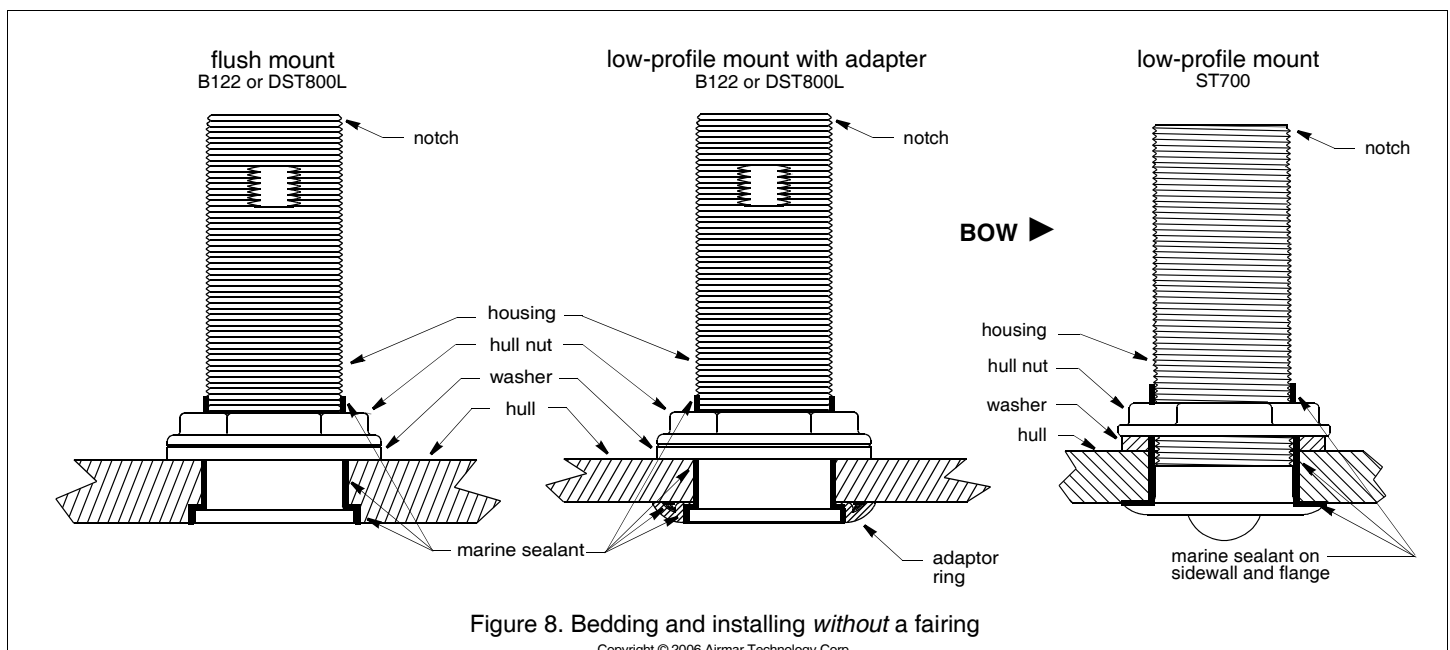
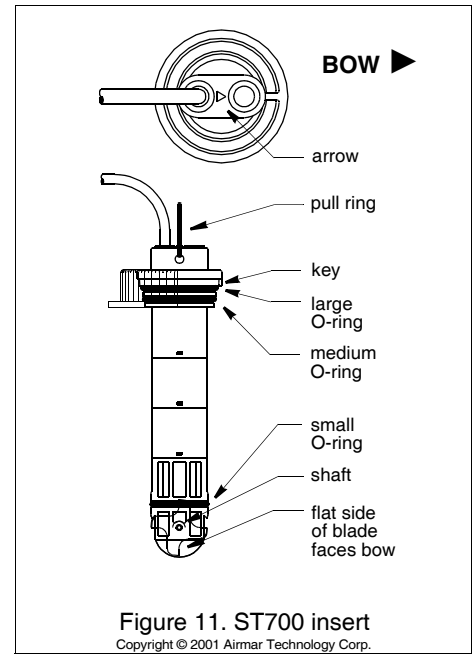
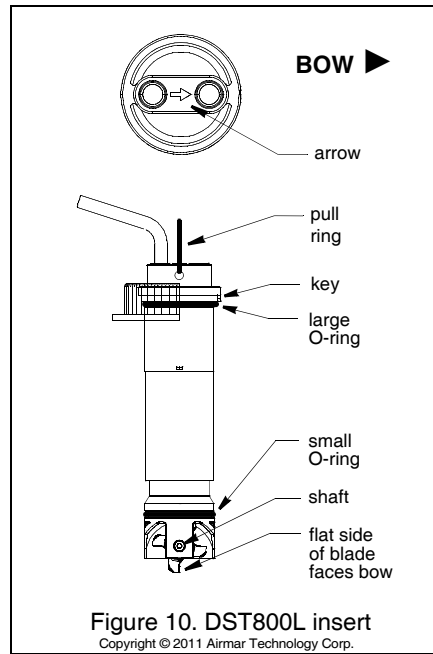
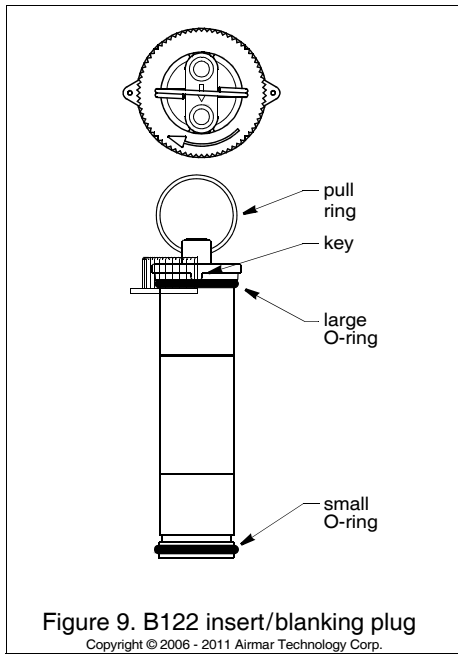

Figure 8. Bedding and installing *without* a fairing

Copyright © 2006 Airmar Technology Corp.



Installing the Insert

1. Slide the cap nut along the cable until it rests on top of the insert. Attach the pull ring capturing the cap nut (see Figure 9, 10, or 11). Attach the pull ring to the blanking plug in a similar fashion.
2. The O-rings must be intact and well lubricated to make a watertight seal. After the marine sealant cures, inspect the O-rings on the insert (replace if necessary) and lubricate them with the silicone lubricant supplied.
3. Slide the insert into the housing. *Point the arrow on the top forward toward the bow.* Seat the insert into place with a twisting motion until the key fits into the notch. Be careful not to rotate the outer housing and disturb the sealant. Screw the cap nut in place and **hand tighten** only. Do not over tighten.
4. Attach the safety wire to prevent the insert from backing out in the unlikely event that the cap nut fails or is screwed on incorrectly (see Figure 12). Wrap one end of the safety wire tightly around the housing and twist it together with the long end. Keeping the wire taut throughout, lead it straight up and through the eye in the cap nut. Loop the wire through the pull ring and twist it securely to itself.

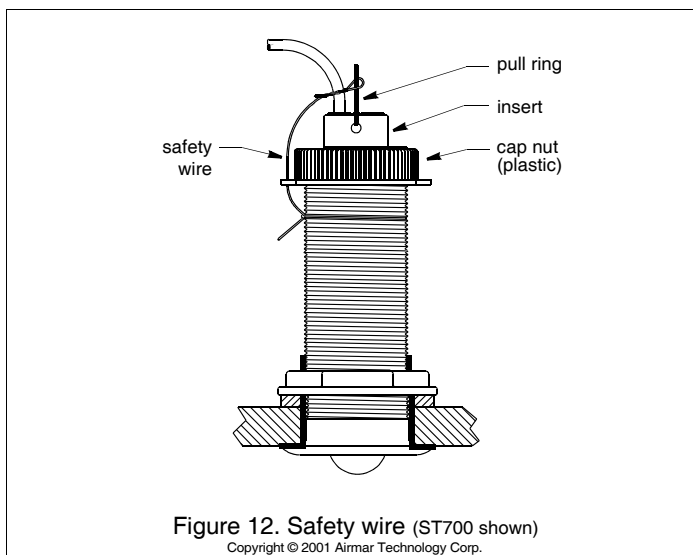

Cable Routing & Connecting

CAUTION: If your sensor came with a connector, do not remove it to ease cable routing. If the cable must be cut and spliced, use Airmar's splash-proof Junction Box No. 33-035 and follow the instructions provided. Removing the waterproof connector or cutting the cable, except when using a water-tight junction box, will void the sensor warranty.

1. Route the cable to the instrument, being careful not to tear the cable jacket when passing it through the bulkhead(s) and other parts of the boat. Use grommet(s) to prevent chaffing. To reduce electrical interference, separate the sensor cable from other electrical wiring and the engine. Coil any excess cable and secure it in place using cable ties to prevent damage.
2. Refer to the echosounder owner's manual to connect the sensor to the instrument.

Checking for Leaks

When the boat is placed in the water, **immediately** check around the thru-hull sensor for leaks. Note that small leaks may not be readily observed. Do not leave the boat in the water for more than 3 hours before checking it again. If there is a small leak, there may be considerable bilge water accumulation after 24 hours. If a leak is observed, repeat the bedding and installing procedures **immediately**.

Installation in a Cored Fiberglass Hull

The core (wood or foam) must be cut and sealed carefully. The core must be protected from water seepage, and the hull must be reinforced to prevent it from crushing under the hull nut allowing the housing to become loose.

CAUTION: Completely seal the hull to prevent water seepage into the core.

1. Drill a 3mm or 1/8" pilot hole from inside the hull. If there is a rib, strut, or other hull irregularity near the selected mounting location, drill from the outside. If the hole is drilled in the wrong location, drill a second hole in a better location. Apply masking tape to the outside of the hull over the incorrect hole and fill it with epoxy.

Fairing—Drill perpendicular to the *waterline* (see Figure 13).

No fairing—Drill perpendicular to the *hull* (see Figure 14).

2. Using the 51 mm or 2" hole saw, cut a hole from outside the hull through the *outer skin* only. Be sure to hold the drill plumb, so the hole will be perpendicular to the water surface.

NOTE: The optimal interior hole diameter is affected by the hull's thickness and deadrise angle. It must be large enough in diameter to allow the core to be completely sealed.

3. Using a minimum 60mm or 2-3/8" hole saw, cut through the *inner skin* and most of the core from inside the hull keeping the drill perpendicular to the hull. The core material can be very soft. Apply only light pressure to the hole saw after cutting through the inner skin to avoid accidentally cutting the outer skin.
4. Remove the plug of core material, so the *inside* of the outer skin and the inner core of the hull is fully exposed. Sand and clean the inner skin, core, and the outer skin around the hole.
5. Coat a hollow or solid cylinder of the correct diameter with wax and tape it in place. Fill the gap between the cylinder and hull with casting epoxy. After the epoxy has set, remove the cylinder.
6. Sand and clean the around the hole, inside and outside, to ensure that the marine sealant will adhere properly to the hull. If there is any petroleum residue inside the hull, remove it with either mild household detergent or a weak solvent (alcohol) before sanding.
7. If this is an installation with a fairing, follow the same procedure to prepare the hull for the anti-rotation bolt ("Installation in a Cored Fiberglass Hull", steps 2 through 6). Use a 11 mm or 3/8" drill bit to cut the *outer skin* and a min. (19mm or 3/4") drill bit for the hull's *inner skin*.
8. Proceed with the installation instructions.

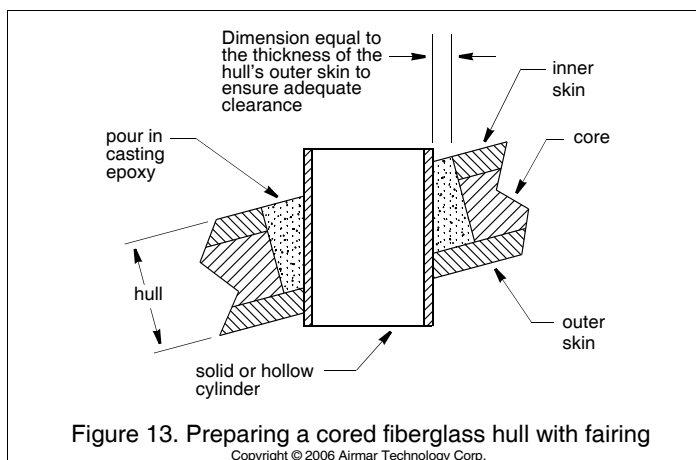

Operation, Maintenance, Repair, & Parts

Using the Blanking Plug

To protect the insert, use the blanking plug:

- When the boat will be kept in salt water for more than a week.
- When the boat will be removed from the water.
- When aquatic growth buildup is suspected due to inaccurate readings from the instrument.

1. The O-rings must be intact and well lubricated to make a watertight seal. On the blanking plug, inspect the O-rings (replace if necessary) and lubricate them with the silicone lubricant supplied or petroleum jelly (Vaseline®) (see Figure 9).
2. Remove the insert from the housing by removing the safety wire and unscrewing the cap nut (see Figure 12).
3. With the blanking plug ready in one hand, pull the insert most of the way out. Remove the insert and rapidly replace it with the blanking plug. Seat it into place with a pushing twisting motion until the key fits into the notch in the housing. Screw the cap nut in place and **hand tighten** only. Do not over tighten.
No valve—With practice, only about 250ml (10oz.) of water will enter the boat.
4. Reattach the safety wire to prevent the insert from backing out in the unlikely event that the cap nut fails or is screwed on incorrectly.

Servicing the Insert & Blanking Plug

B122, Blanking Plug—The O-rings must be intact and well lubricated to make a watertight seal. Inspect the spare O-rings and lubricate them with silicone lubricant or petroleum jelly (Vaseline®) (see Figure 9). Install the O-rings.

DST800L, ST700—The water lubricated paddlewheel bearings have a life of up to 5 years on low-speed boats [less than 10kn (11MPH)] and 1 year on high-speed vessels. Paddlewheels can fracture and shafts can bend due to impact with water borne objects and mishandling in boat yards. O-rings must be free of abrasions and cuts to ensure a watertight seal.

1. To remove the old paddlewheel shaft, grasp the end with small diagonal wire cutters and pull (see Figure 10 or 11).
2. Place the new paddlewheel in the cavity with the flat side of the blade facing the same direction as the arrow on the top of the insert.
3. Tap the new shaft into place until the end is flush with the outside wall of the insert.
4. The O-rings must be intact and well lubricated to make a watertight seal. Inspect the spare O-rings and lubricate them with silicone lubricant or petroleum jelly (Vaseline®). Install the O-rings.

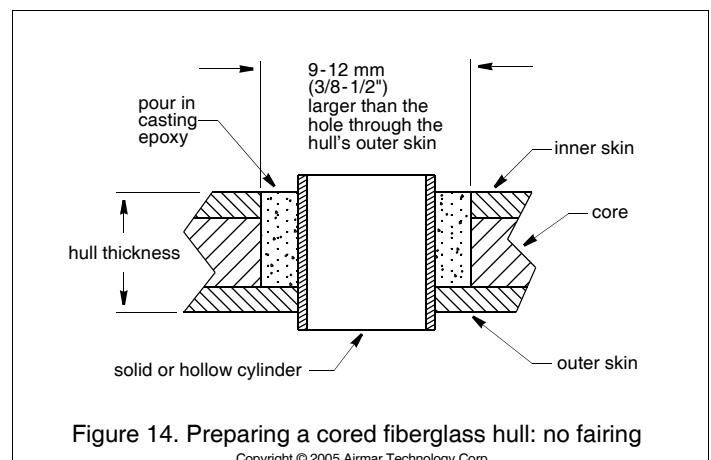

ST700: Valve

How the Valve Works

The valve is not a watertight seal! The sensor incorporates a self-closing valve which minimizes the flow of water into the boat when the insert is removed. The curved flap valve is activated by both a spring and water pressure. Water pushes the flap valve upward to block the opening, so there is no gush of water into the boat. Always use the insert or the blanking plug secured with the safety wire for a watertight seal.

Servicing the Valve Assembly—Should the valve fail, remove it for servicing.

1. Inspect the O-rings on the blanking plug and lubricate them with silicone lubricant or petroleum jelly (Vaseline®).
2. Remove the insert from the housing.
3. Remove the snap ring from the valve assembly using a screwdriver to pry the end of the ring free. Lift the ring out (see Figure 15).
4. Slide the valve assembly upward and out of the housing slowly. The flap valve retainer pin is a loose slip-fit and may slide out when the assembly is removed.
5. Hold the cap nut on the blanking plug while sliding it into the housing with the arrow on the top pointing forward toward the bow. Seat the plug with a twisting motion until the key fits into the notch. Screw the cap nut in place. **Hand tighten** only. Do not over tighten. Reattach the safety wire (see Figure 12).
6. Clean, repair, or replace the valve assembly so the flap valve moves freely and seats against the valve housing.
7. To reinstall the valve assembly, first reassemble the flap valve in the valve housing with the retainer pin and spring in place (see Figure 15).
8. Remove the blanking plug. Slide the valve assembly into the housing with the flap valve pointing downward. Insert the snap ring being certain that it *locks into the groove* in the housing wall.
9. Hold the cap nut on the blanking plug/insert while sliding it into the housing with the arrow on the top pointing forward toward the bow. *Seat it into place with a twisting motion until the key fits into the notch.* Screw the cap nut in place **Hand tighten** only. Do not over tighten.
10. Reattach the safety wire to prevent the insert from backing out in the unlikely event that the cap nut fails or is screwed on incorrectly (see Figure 12).

Cleaning

Aquatic growth can accumulate rapidly on the depth transducer face and impede or freeze the paddlewheel's rotation reducing performance within weeks. Clean the insert with a Scotch-Brite® scour pad and mild household detergent, being careful to avoid scratching the depth transducer. If there is a paddlewheel and fouling is severe, remove the paddlewheel and lightly wet sand it with fine grade wet/dry paper.

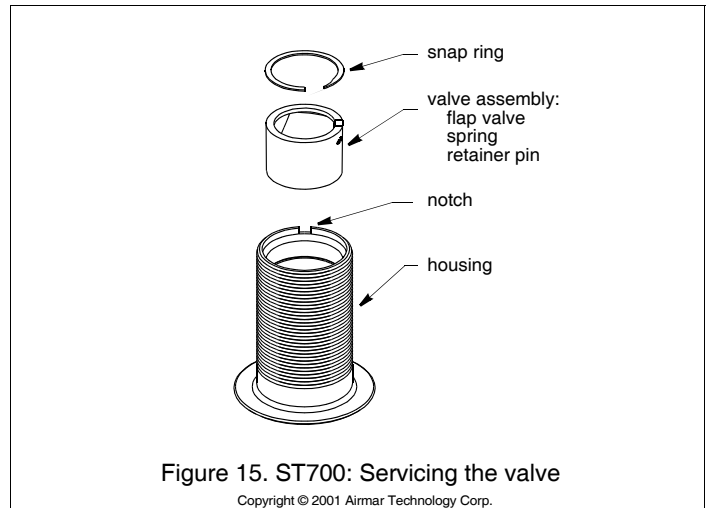

Figure 15. ST700: Servicing the valve

Copyright © 2001 Airmar Technology Corp.

Winterizing

After the boat has been hauled for winter storage, remove the blanking plug to let the water drain away before reinserting it. This will prevent any water from freezing around the blanking plug and possibly cracking it.

Replacement Sensor & Parts

The information needed to order a replacement sensor is printed on the cable tag. Do not remove this tag. When ordering, specify the part number, date, and frequency in kHz. For convenient reference, record this information on page one.

Lost, broken, and worn parts should be replaced immediately

Model	Fairing	Cap Nut	Hull Nut	Adaptor Ring	Blanking Plug	Pdwl & O-rings
B122	33-409-01	02-131-01 (bronze) 04-234-1 (plastic)	02-030	33-634-02	33-414	—
DST800L	33-409-01	02-131-01 (bronze) 04-234-1 (plastic)	02-030	33-634-02	33-414	33-398-04
ST700	—	02-131-01 (bronze) 04-234-1 (plastic)	02-030	—	20-306-01	33-250

Obtain parts from your instrument manufacturer or marine dealer.

Gemeco
(USA)

Tel: 803.693.0777

Fax: 803.693.0477

Email: sales@gemeco.com

Airmar EMEA

Tel: +33.(0)2.23.52.06.48

(Europe, Middle East, Africa)

Fax: +33.(0)2.23.52.06.49

Email: sales@airmar-emea.com