

WX Series



Photo courtesy of MOBA

## WX Ultrasonic WeatherStation® Instruments for Land Applications

Delivering a Compact, Affordable Instrument  
for Informed Decision-Making

### Available Models: 110WX, 150WX, 200WX

Whether you are harvesting crops, operating equipment, preparing for bad weather or responding to a hazardous event; understanding the weather is important. The WX Series allows users to make informed decisions based on site specific information, resulting in improved efficiency, reduced risks and overall cost savings. Various model options are available depending on the application and requirements.

The WX Series WeatherStation Instruments offer a truly best-in-class solution at a better price point compared to any other weather monitoring system on the market today!



Actual  
Size

### FEATURES

- Model 110WX – Measures apparent wind speed and angle, barometric pressure, air temperature, relative humidity, calculated dew point, heat index and wind chill temperature
- Models 150WX and 200WX – Includes all 110WX functionality plus internal compass and GPS (for true wind speed and direction), GPS position, speed over ground, course over ground
- Model 200WX – Best-in-class dynamic stabilization via three-axis compass and three-axis rate gyro
- UV stabilized, compact housing

 **AIRMAR**  
TECHNOLOGY CORPORATION

*Sensing Technology*

# Product Models to Satisfy Multiple Weather Needs



Now available on iTunes — OnSiteWX  
The innovative App for real-time weather data!



110WX



150WX



200WX

	Apparent & True Wind Models		
	Apparent Wind Model	Recommended for Moving Vehicle Applications	Recommended for Dynamic Moving Vehicle Applications
Apparent wind speed and angle	✓	✓	✓
True wind speed and direction		✓	✓
Barometric Pressure	✓	✓	✓
Ultrasonic wind readings up to 90 mph (78 knots, 40 m/s)	✓	✓	✓
Air temperature plus calculated wind chill	✓	✓	✓
10 Hz GPS (Position, COG, SOG)		✓	✓
Two-axis solid state compass		✓	
Three-axis accelerometer for pitch and roll		✓	✓
Three-axis solid-state compass with dynamic stabilization: Better than 1° static compass accuracy Best-in-class 2° dynamic compass accuracy			✓
Three-axis rate gyros provide rate-of-turn data			✓
Best-in-class pitch and roll accuracy			✓
Optional field-serviceable relative humidity Calculated dew point Calculated heat index	✓	✓	✓
Output options include: NMEA 0183 (RS422) and NMEA2000® (CAN Bus) NMEA 0183 (RS232) and NMEA2000® (CAN Bus)	✓	✓	✓

## WeatherCaster™ Software

### Developer Assistance

- Enable/disable functionality
- Optimize communications bandwidth NMEA 0183 (RS232, RS422)
- Change sampling rate (output interval)

### Field Installation Assistance

- Enable/disable functionality
- Sensor orientation
- Compass calibration
- Temperature offset
- Select specific device on a NMEA2000® network
- Alarms for wind speed and barometric pressure
- Altitude offset
- More accurate GPS position in 2D mode
- More accurate BP reading

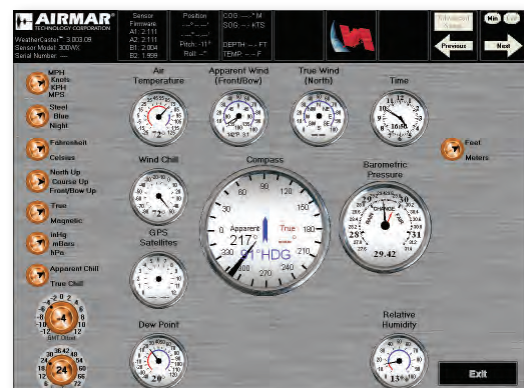

# Achieving Best-in-Class Product Specifications

## SPECIFICATIONS

### Wind Speed Range:

— 0 knots to 78 knots (0 MPH to 90 MPH, 0 m/s to 40 m/s)

### Wind Speed Resolution:

— 0.1 knot (0.1 MPH, 0.1 m/s)

### Wind Speed Accuracy @ 0°C to 55°C (32°F to 131°F), no precipitation\*:

#### — Low Wind Speeds:

0-10 knots; 1 knot RMS +10% of reading  
(0 MPH to 11.5 MPH; 1.1 MPH + 10% of reading)  
(0 m/s to 5 m/s; 0.5 m/s + 10% of reading)

#### — High Wind Speeds:

10-78 knots; 2 knots RMS or 5%, whichever is greater  
(11.5 MPH to 90 MPH; 2.3 MPH or 5%, whichever is greater)  
(5 m/s to 40 m/s; 1 m/s or 5%, whichever is greater)

### Wind Speed Accuracy in wet conditions\*\*:

— 5 knots RMS (5.7 MPH RMS, 2.5 m/s RMS)

### Wind Direction Range: 0° to 360°

### Wind Direction Resolution: 0.1°

### Wind Direction Accuracy @ 0°C to 55°C (32°F to 131°F), no precipitation\*:

#### — Low Wind Speeds (5° RMS typical):

4-10 knots (4.6 MPH to 11.5 MPH, 2 m/s to 5 m/s)

#### — High Wind Speeds (2° RMS typical):

>10 knots (>11.5 MPH, >5 m/s)

### Wind Direction Accuracy in wet conditions\*\* (8° RMS Typical):

>8 knots (>9.2 MPH, >4 m/s)

### Compass Accuracy:

— 1° RMS when level—(150WX only)

— 1° static heading accuracy; 2° dynamic heading accuracy—200WX only

### Pitch and Roll Range / Accuracy: ±50° / <1°—150WX & 200WX

### Air Temperature Range: -40°C to 55°C (-40°F to 131°F)

### Air Temperature Resolution: 0.1°C (0.1°F)

### Air Temperature Accuracy:

±1.1°C (±2°F)\* @ >4 knots wind (>4.6 MPH wind) (>2 m/s wind)

### Barometric Pressure Range:

300 mbar to 1100 mbar (24 inHg to 33 inHg, 800 hPa to 1100 hPa)

### Barometric Pressure Resolution: 0.1 mbar (0.029 inHg, 0.1 hPa)

### Barometric Pressure Accuracy:

±1 mbar (±0.029 inHg, ±1 hPa) when altitude correction is available

### Relative Humidity Range: 10% to 95% RH

### Relative Humidity Accuracy\*: ±5% units RH

### GPS Position Accuracy:

3 m (10') with WAAS/EGNOS (95% of the time)—150WX & 200WX

### Operating Temperature Range: -25°C to 55°C (-13°F to 131°F)

### Supply Voltage: 9 VDC to 40 VDC

### Supply Current (@ 12 VDC):

— (<50 mA) <0.6W —110WX

— (<85 mA) <1.0W —150WX

— (<105 mA) <1.25W —200WX

### Weight: 300 grams (0.8 lb)

### Communication Interface: NMEA 0183 (RS422 or RS232) and NMEA2000® (CAN bus)\*\*\*

### Mounting Thread Size on Base: Standard 1"-14 UNS (3/4" NPT optional)

### Certifications and Standards:

CE, IPX6 (Relative Humidity/IPX4), RoHS, IEC61000-4-2, IEC60945

IEC60950\_1C, IEC60950\_22A, EN55022, EN55024, EN15014982

### RMS—Root Mean Square

\*When the wind speed is less than 2 m/s (4.6 MPH) and/or air temperature is below 0°C (32°F), wind, temperature, and relative humidity readings will be less accurate.

\*\*Wet conditions include moisture, rain, frost, dew, snow, ice and/or sea spray in the wind channel.

\*\*\*Airmar has made the address claiming modifications to enable compatibility with the ISO 11783 communication protocol for the agriculture industry – that is based on the SAE J1939 protocol.

## PART NUMBERS

**110WX:** 44-820-1-01, RH, NMEA 0183 (RS422) and NMEA2000® (CAN Bus)

**110WX:** 44-823-1-01, NMEA 0183 (RS422) and NMEA2000® (CAN Bus)

**110WX:** 44-843-1-01, RH, NMEA 0183 (RS232) and AG (CAN Bus)

**150WX:** 44-832-1-01, RH, NMEA 0183 (RS422) and NMEA2000® (CAN Bus)

**150WX:** 44-833-1-01, NMEA 0183 (RS422) and NMEA2000® (CAN Bus)

**150WX:** 44-834-1-01, RH, NMEA 0183 (RS232) and AG (CAN Bus)

**200WX:** 44-835-1-01, NMEA 0183 (RS422) and NMEA2000® (CAN Bus)

**200WX:** 44-837-1-01, RH, NMEA 0183 (RS422) and NMEA2000® (CAN Bus)

**200WX:** 44-847-1-01, NMEA 0183 (RS232) and NMEA2000® (CAN Bus)

\* Cables sold separately

RH— Relative Humidity

## DIMENSIONS

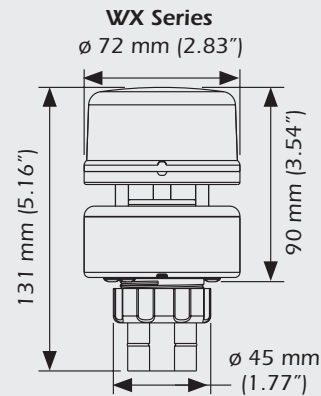

## DATA OUTPUT PROTOCOL

### NMEA 0183 Sentence Structure

\$GPDTM..... GPS Datum Reference  
 \$GPGGA..... GPS Fix Data  
 \$GPGLL..... Geographic Position—Latitude and Longitude  
 \$GPGSA..... GNSS DOP and Active Satellites  
 \$GPGSV..... Satellites in View  
 \$GPRMC..... Recommended Minimum GNSS  
 \$GPVTG..... COG and SOG  
 \$GPZDA..... Time and Date  
 \$HCHDG..... Heading, Deviation, and Variation  
 \$HCHDT..... True Heading  
 \$HCTHS..... True Heading and Status  
 \$TIROT..... Rate of Turn  
 \$WIMDA..... Meteorological Composite  
 \$WIMWD..... Wind Direction and Speed  
 \$WIMWV..... Wind Speed and Angle  
 \$WIMWR..... Relative Wind Direction and Speed  
 \$WIMWT..... True Wind Direction and Speed  
 \$YXXDR..... Transducer Measurements

### NMEA2000® Output Message Structure

59392..... ISO Acknowledgement  
 060928..... ISO Address Claim  
 126208..... Acknowledge Group Function  
 126464..... PGN List  
 126992..... System Time  
 126996..... Product Information  
 126998..... Configuration Information  
 127250..... Vessel Heading  
 127251..... Rate of Turn  
 127257..... Attitude  
 127258..... Magnetic Variation  
 129025..... Position and Rapid Update  
 129026..... COG and SOG, Rapid Update  
 129029..... GNSS Position Data  
 129033..... Time and Date  
 129044..... Datum  
 129538..... GNSS Control Status  
 129539..... GNSS DOPs  
 129540..... GNSS Sats in View  
 130306..... Wind Data  
 130310..... Environmental Parameters  
 130311..... Environmental Parameters  
 130312..... Temperature  
 130313..... Humidity  
 130314..... Actual Pressure  
 130323..... Meteorological Station Data

# Understanding True and Apparent Wind

Virtually all mechanical and ultrasonic anemometers report apparent wind speed and direction. The Airmar WX Series is unique because it calculates both true and apparent wind speed and direction. These wind readings are the same if the unit is mounted in a fixed location. However, if the WX Series is mounted on a moving vehicle, the apparent wind is the wind you would feel on your hand if you held it out the window while going down the highway. Since the WX Series has a built in GPS and compass, it calculates the true wind based upon the apparent wind, speed of the vehicle, and compass heading.

True wind information is significant for numerous applications on hazardous response vehicles. True wind speed and direction is also mission-critical. When en route to an emergency situation, first responders can use the true wind readings to predict wind conditions at the disaster site before they even arrive, giving vital information for planning operations and staging apparatus.

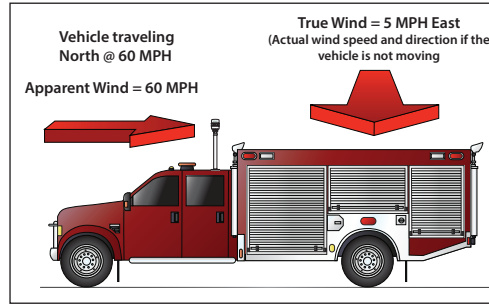

Airmar's WX Series products are the only all-in-one unit to offer true and apparent wind speeds without additional sensors.

Each WeatherStation Instrument is factory calibrated in a wind tunnel at our state-of-the-art facility located in Milford, New Hampshire, USA.

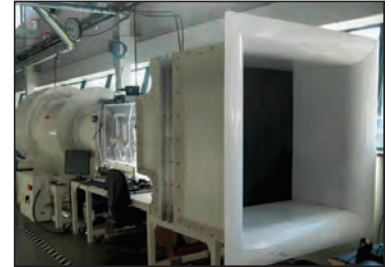

# Performing Above and Beyond Competitive Products on the Market

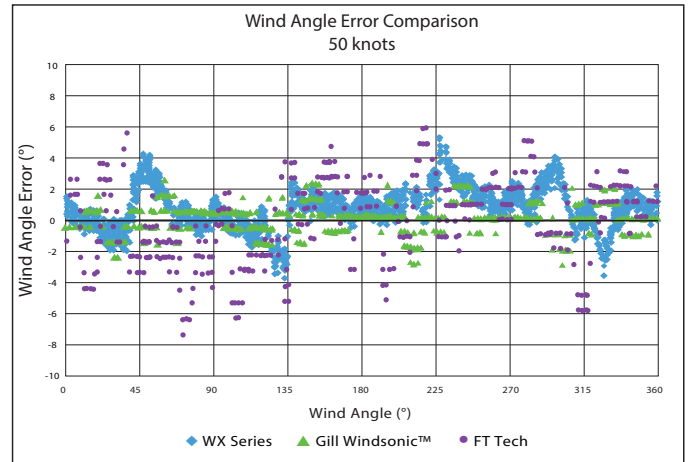
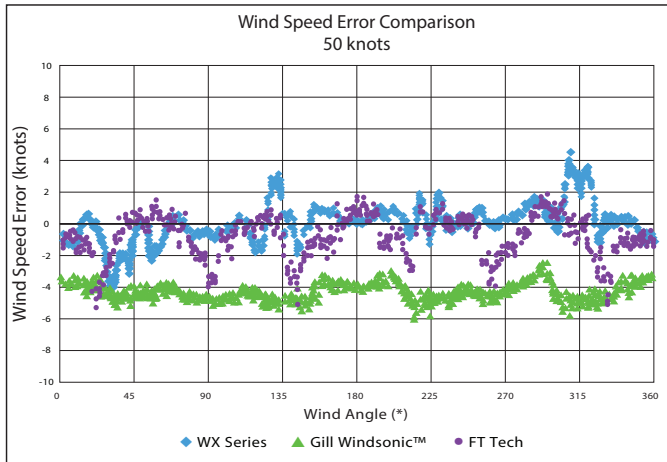

[www.airmar.com](http://www.airmar.com)



*Sensing Technology*

©2016 Airmar Technology Corporation

As Airmar constantly improves its products, all specifications are subject to change without notice. All Airmar products are designed to provide high levels of accuracy and reliability, however they should only be used as aids to navigation and not as a replacement for traditional navigation aids and techniques. WeatherStation® and WeatherCaster™ are registered trademarks and trademarks of Airmar Technology Corporation. Other company or product names mentioned in this document may be trademarks or registered trademarks of their respective companies, which are not affiliated with Airmar.

WX\_Series\_LAND\_APP\_rE 03/17/16